

Proportional pressure relief valves series R5V*P2 are based on the mechanically adjusted series R5V. The additional proportional unit between the mechanical pilot valve and the main stage allows continuous pressure adjustment.

The optimum performance can be achieved in combination with the digital amplifier module PCD00A-400.

Features

- Continuous adjustment by proportional solenoid
- R5V with 3-port body
 - 4 sizes (SAE 3/4", 1", 1 1/4", 1 1/2")
 - SAE61 and SAE62 flange
- 3 pressure stages
- With mechanical maximum pressure adjustment

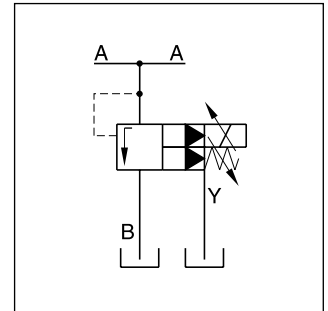

R5V*P2

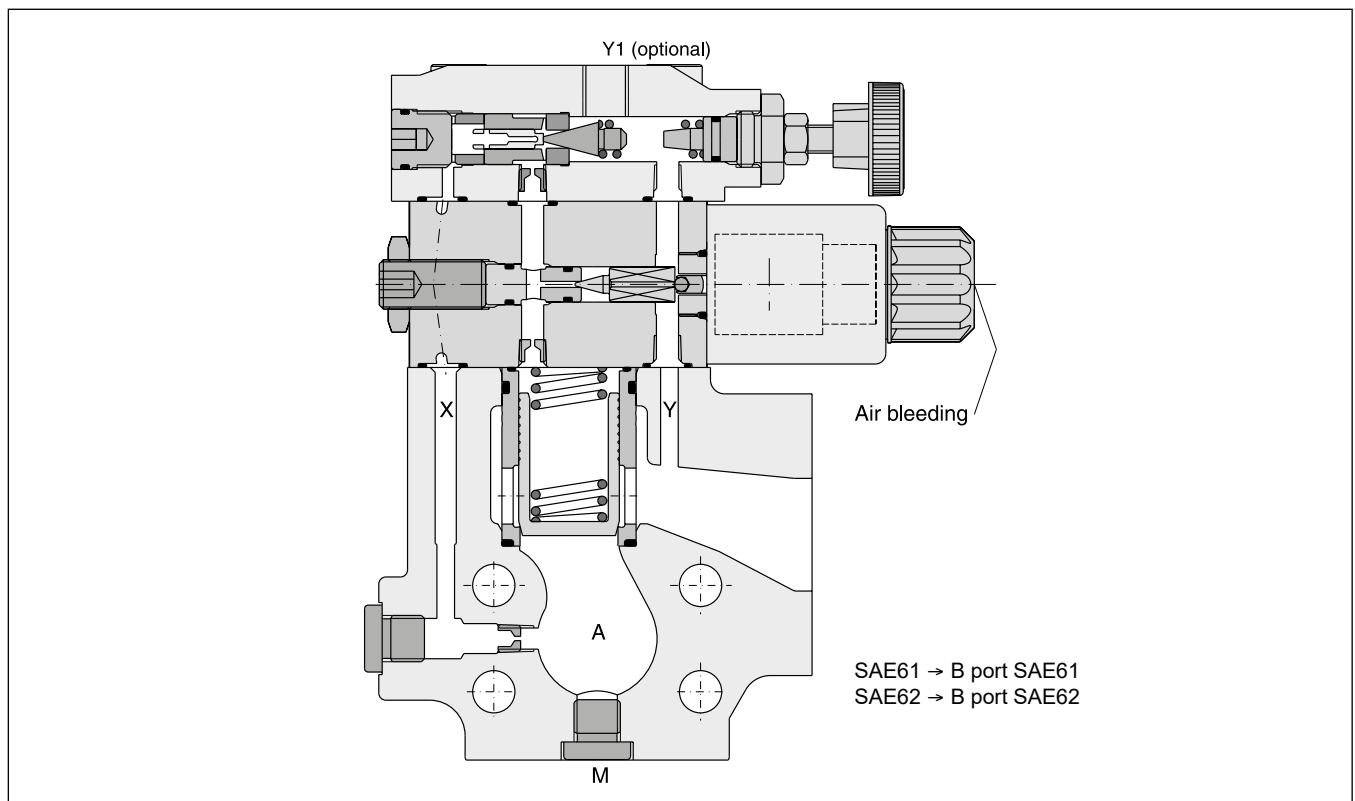

Ordering Code

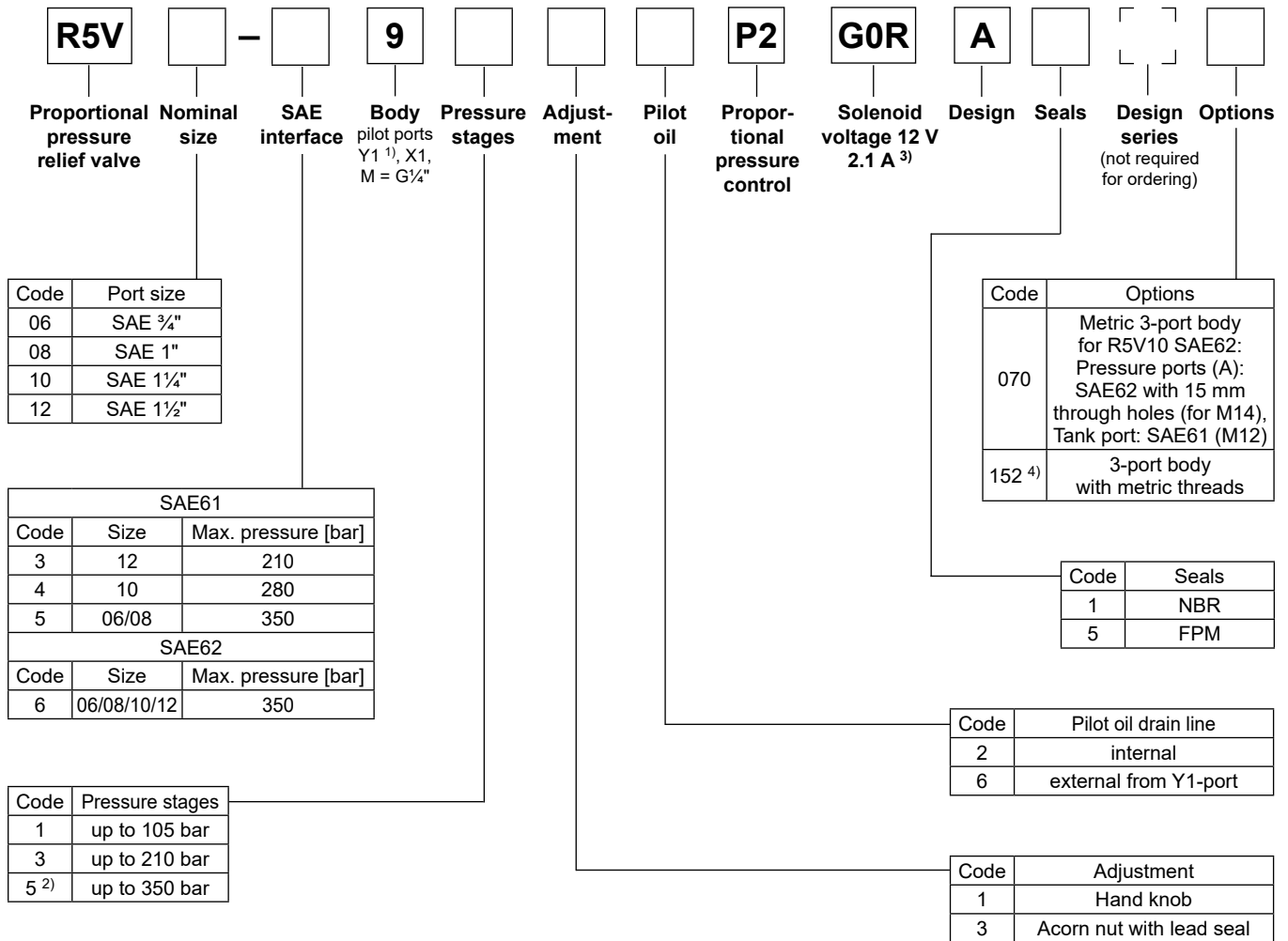

9

¹⁾ Y1 only available at external drain (pilot oil code 6).

²⁾ R5V10-495 up to 280 bar.

³⁾ Onboard electronics on request.

⁴⁾ R5V08 SAE62: Tank port SAE61 (M10).

General				
Size	06 (¾")	08 (1")	10 (1¼")	12 (1½")
Mounting	Flanged according to SAE61 (size 12 = SAE62)			
Mounting position	unrestricted			
Ambient temperature [°C]	-20...+60			
MTTF _D value [years]	75			
Weight [kg]	5.4	6.4	7.0	9.8
Hydraulic				
Max. operating pressure [bar]				
SAE61 Ports A, B	350	350	280	210
Port Y1	30	30	30	30
SAE62 Ports A, B	350	350	350	350
Port Y1	30	30	30	30
Pressure stages [bar]	105, 210, 350			
Nominal flow [l/min]	90	300	600	600
Fluid	Hydraulic oil according to DIN 51524			
Fluid temperature [°C]	-20...+70 (NBR: -25...+70)			
Viscosity permitted [cSt] / [mm ² /s]	20...400			
Viscosity recommended [cSt] / [mm ² /s]	30...80			
Filtration	ISO 4406 (1999); 18/16/13			
Electrical (proportional solenoid)				
Duty ratio	100 % ED; CAUTION: coil temperature up to 150 °C possible			
Protection class	IP65 in accordance with EN 60529 (with correctly mounted plug-in connector)			
Code	G0R			
Supply voltage [V]	12 V =			
Max. current [A]	2.1			
Coil resistance at 20 °C [Ohm]	4.28			
Solenoid connection	Connector as per EN 175301-803			
Power amplifier, recommended	PCD00A-400			

Signal/pressure curve R5V*P2

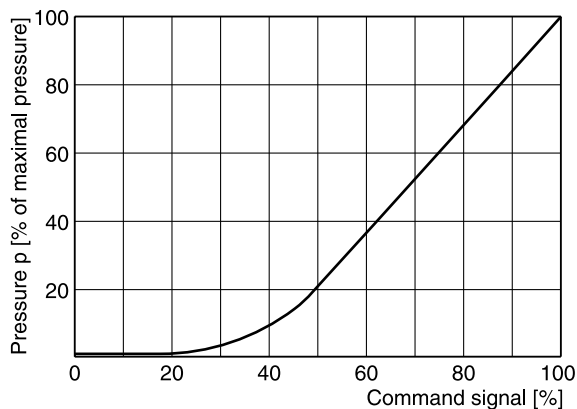

**p/Q performance curve ¹⁾
R5V06*P2**

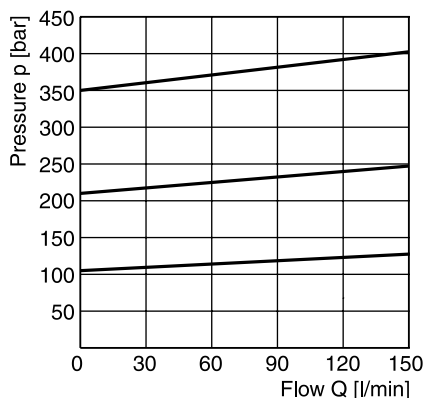

R5V08*P2

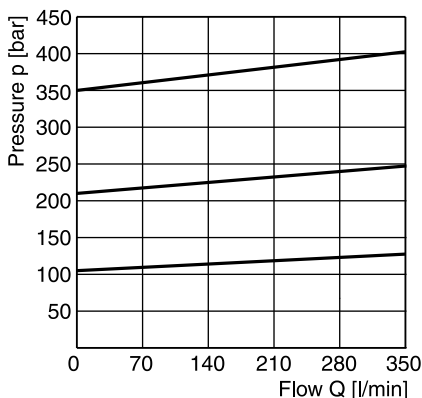

R5V10*P2

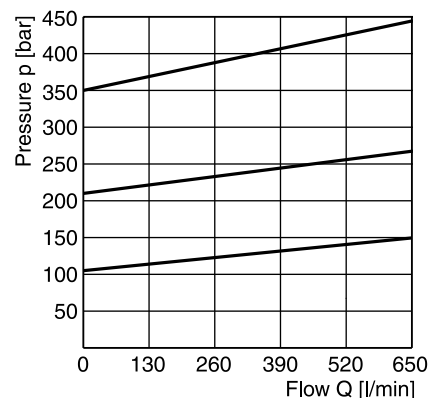

9

**Minimum pressure curve ¹⁾
R5V06*P2**

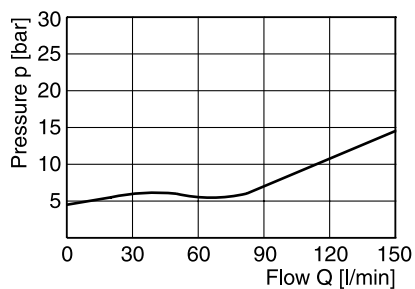

R5V08*P2

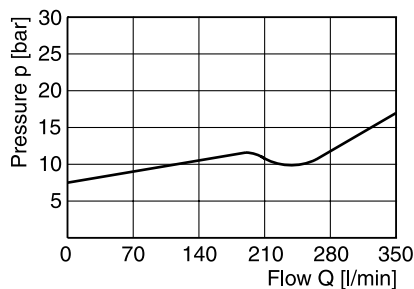

R5V10*P2

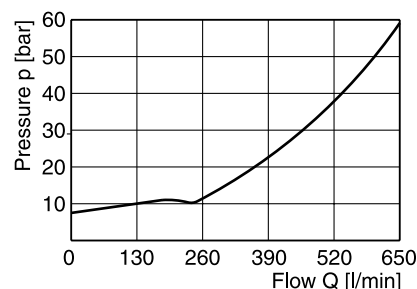

All characteristic curves measured with HLP46 at 50 °C.

¹⁾The performance curves are measured with external drain. For internal drain the tank pressure has to be added to curve.

R5V*P2 3-port

Seal kits		
NG	NBR	FPM
06	S16-91850-0	S16-91850-5
08	S16-91851-0	S16-91851-5
10	S16-91852-0	S16-91852-5
12	S26-27421-0	S26-27421-5
Prop. section P2 *	S26-58473-0	S26-58473-5

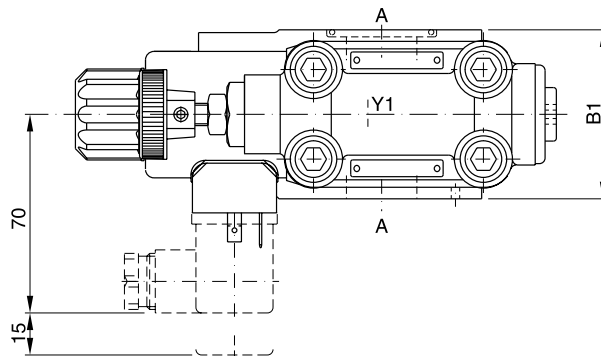

Important:
 On initial start up and
 after long shut down periods
 bleed air from this plug.

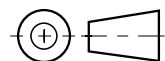
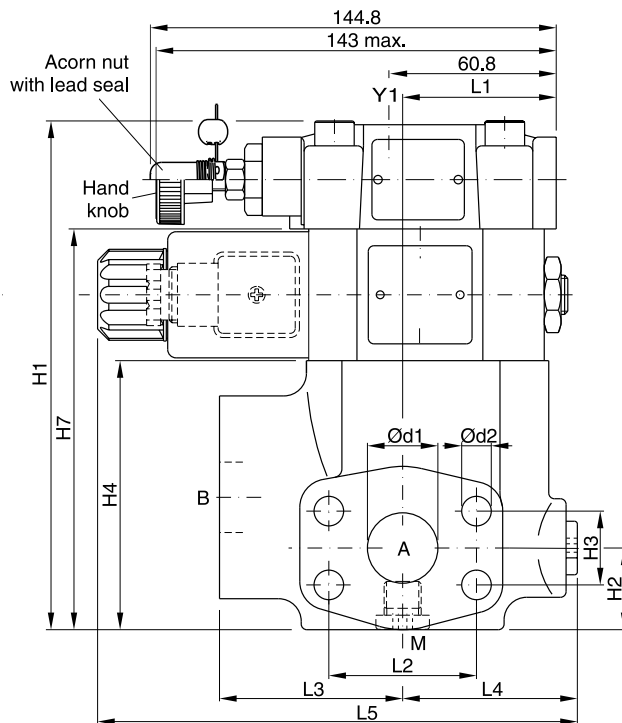
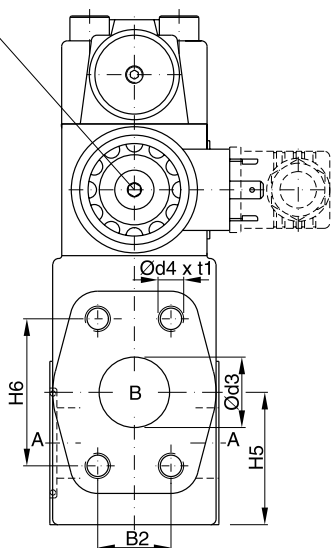

9

SAE61

NG	B1	B2	H1	H2	H3	H4	H5	H6	H7	L1	L2	L3	L4	L5	d1	d2	d3	d4 (option 152)	t1
06	60	22.2	166	29.5	22.2	81	41	47.6	128	50.3	47.6	63	60	174.6	19	10.5	19	3/8"-16 UNC (M10)	20
08	60	26.2	188	30.5	26.2	103	47	52.4	150	55.8	52.4	65	62	177	25	10.5	25	3/8"-16 UNC (M10)	23
10	75	30.2	198	37.5	30.2	113	65	58.7	160	57.8	58.7	61	68	179.1	32	12.5	30	7/16"-14 UNC (M12)	22
12	80	35.7	225	72	35.7	140	73	69.8	187	37.3	69.8	92.5	59.2	186.8	38	13.5	38	1/2"-13 UNC (M12)	27

SAE62

NG	B1	B2	H1	H2	H3	H4	H5	H6	L1	L2	L3	L4	L5	d1	d2	d3	d4 (option 152)	t1
06	60	23.8	119	29.5	23.8	81	41	50.8	50.3	50.8	63	60	152	19	10.5	19	3/8"-16 UNF (M10)	20
08	60	27.8	141	30.5	27.8	103	47	57.2	55.8	57.2	65	62	149	25	12.5	25	7/16"-14 UNC (M10) ¹⁾	22
10	75	31.8	151	37.5	31.8	113	65	66.7	57.8	66.7	61	68	150.5	32	13.5	30	1/2"-13 UNC (M12)	24
12	80	36.5	178	72	36.5	140	73	79.4	37.3	79.4	92.5	59.2	171.2	38	17	38	5/8"-11 UNC (M16)	33

Port	Function	Port size			
		R5V06	R5V08	R5V10	R5V12
A (2)	Pressure	3/4" SAE61/62	1" SAE61/62	1 1/4" SAE61/62	1 1/2" SAE61/62
B	Tank	3/4" SAE61/62	1" SAE61/62	1 1/4" SAE61/62	1 1/2" SAE61/62
Y1	External drain	G 1/4"	G 1/4"	G 1/4"	G 1/4"
M	Pressure gauge	G 1/4"	G 1/4"	G 1/4"	G 1/4"

* Please combine seal kit of one size with seal kit of Prop. section P2 for complete seal kit.

¹⁾ T-port SAE61.