

**Description**

- Variable displacement, axial piston pump for open-circuit applications
- Continuous operation at pressures up to 280 bar
- High drive speed models for mobile markets and low noise models for industrial markets
- Quiet and efficient control capability
- Cam bearing design

**Benefits**

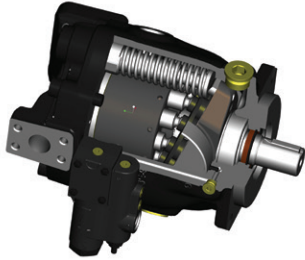

- Compact overall package size
- High power density
- Many different standard control options
- Modular controls for easy conversions
- High operating efficiency for lower power consumption and reduced heat generation
- Elastomer seals that eliminate gaskets and external leakage
- Simple hydraulic controls with “no-leak” adjustments
- Fast and stable compensator response
- SAE and ISO standard mounting flanges and ports
- Long life, roller shaft bearings
- Long life, low friction, hydrostatically balanced swash plate saddle bearings
- Full power through-drive capability
- Multiple case drain ports for various mounting orientations
- Optional minimum and maximum displacement adjustments
- Easy to service

**Technical Data**

Model	P1/PD 018	P1/PD 028	P1/PD 045	P1/PD 060	P1/PD 075	P1/PD 085	P1/PD 100	P1/PD 140
Maximum Displacement, cm <sup>3</sup> /rev cu.in./rev	18 1.10	28 1.71	45 2.75	60 3.66	75 4.58	85 5.19	100 6.01	140 8.54
Outlet Pressure – Continuous	280 bar (4060 psi)					250 bar (3600 psi)	280 bar (4060 psi)	
Intermittent*	320 bar (4640 psi)					300 bar (4350 psi)	320 bar (4640 psi)	
Peak	350 bar (5075 psi)					320 bar (4600 psi)	350 bar (5075 psi)	
P1 Maximum Speed (1.3 bar abs inlet), rpm	3500	3400	3100	2800	2700	2700	2500	2400
P1 (1.0 bar abs inlet), rpm	3300	3200	2800	2500	2400	2400	2250	2100
P1 (0.8 bar abs inlet), rpm	2900	2900	2400	2200	2100	2100	1900	1800
PD Maximum Speed (1.0 bar abs inlet), rpm	1800							
PD (0.8 bar abs inlet), rpm	1800							
Minimum Speed, rpm	600							
Inlet Pressure – Maximum	11 bar absolute (160 psi)							
Rated	1.0 bar absolute (14.5 psi)							
Minimum	0.8 bar absolute (11.6 psi)							
Case Pressure – Peak, bar	4.0 bar absolute (58 psi) and less than 0.5 bar (7.3 psi) above inlet pressure							
Rated, bar	2.0 bar absolute (29 psi) and less than 0.5 bar (7.3 psi) above inlet pressure							
Fluid Temperature Range, °C °F	-40 to +95 -40 to +203							
Fluid Viscosity – Rated, cSt	7 to 160							
Optimum Range, cSt	14-50 cSt.							
Max. Intermittent, cSt	5000 (for cold starting)							
Min. Intermittent, cSt	5							
Fluid Contamination – Rated, ISO	20/18/14							
Weight – End Port, kg (lb)	13.4 (29.5)	17.7 (39.0)	23 (50)	29 (64)	30 (66)	30 (66)	51 (112)	66 (145)
Side Port, kg (lb)	14.2 (31.3)	18.1 (40.0)	24 (52)	30 (67)	31 (68)	31 (68)	53 (117)	67 (147)
Thru-Drive, kg (lb)	15 (34)	22 (48)	27 (59)	34 (75)	35 (77)	35 (77)	55 (121)	82 (180)
Moment of Inertia kg-mm <sup>2</sup>	760	1555	3208	4548	5041	5041	12027	21400
Moment of Inertia Thru-Drive, kg-mm <sup>2</sup>	793	1618	3268	4687	5207	5207	12402	22343

\*Intermittent is defined as less than 10% of operation time, not exceeding 20 successive seconds.

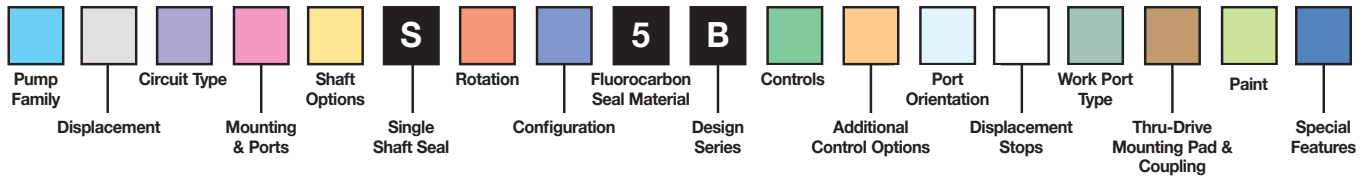

Pump Family	
P1	Mobile
PD	Industrial

Displacement	
018	18cc/rev
028	28cc/rev
045	45cc/rev
060	60cc/rev
075	75cc/rev
085	85cc/rev
100	100cc/rev
140	140cc/rev

Circuit Type	
P	Open Circuit - One Side of Center
X	Open Circuit - Overcenter (45-75, 100-140cc with P, T, S, U controls only)

Mounting & Ports	
S	SAE mount; SAE work & aux ports
A	SAE mount; Metric work ports; BSPP aux ports
M	ISO mount; Metric work & aux ports
B	ISO mount; Metric work ports; BSPP aux ports
C	2-bolt SAE C mount; SAE work & aux ports (60-85cc only)
D	2-bolt SAE C mount; metric work ports; BSPP aux ports (60-85cc only)
J	2-bolt SAE-B mount; SAE work & aux ports (60cc only)
K	2-bolt SAE-B mount; Metric work ports; BSPP aux ports (60cc only)

Shaft Options	
01	SAE Spline
02	SAE Keyed
04	ISO Keyed
06 <sup>1</sup>	SAE Spline (18 & 100cc only)
08	SAE-B 13T Spline (28 & 45cc only)
09	SAE-BB 15T Spline (60cc only)
10	SAE-B 13T Spline (60cc only; Not with thru drive)

<sup>1</sup> 18cc de-rated to 210 bar

Rotation	
R	Clockwise
L	Counterclockwise

Configuration	
M	Mobile (P1)
S	Industrial (PD)
U <sup>2</sup>	Universal (45-140cc only)

<sup>2</sup> Comes with torque limiter ports drilled in the housing

Controls	
C0	Pressure Limiter
L0	Load sensing & pressure limiter
L2	Load sensing with bleed & pressure limiter
AM	Remote pressure limiter
AN	Remote pressure limiter with D03 interface
AE	Prop. Pressure limiter (Min default - 12VDC)
AF	Prop. Pressure limiter (Min default - 24VDC)
AG <sup>3</sup>	Prop. Pressure limiter (Max default - 24VDC)
AH <sup>3</sup>	Prop. Pressure limiter (Max default - 12VDC)

Electronic Displacement Controls	
P0	Min default; No Pmax override; 12 VDC
PM	Min default; No Pmax override; 24 VDC
T0	Max default; No Pmax override; 12 VDC
TM	Max default; No Pmax override; 24 VDC
S0	Min default; Pmax override; 12 VDC
SM	Min default; Pmax override; 24 VDC
U0	Max default; Pmax override; 12 VDC
UM	Max default; Pmax override; 24 VDC

<sup>3</sup> Requires application review. Consult factory.

Additional Control Options	
0	No other options
2	Cam sensor (mandatory with P, T, S, U controls)
3 <sup>4</sup>	Unload Valve - 12VDC (C0 or L0 control only)
6 <sup>4</sup>	Unload Valve - 24VDC (C0 or L0 control only)
4	210 bar pressure limit (AG or AH control only)
7	280 bar pressure limit (AG or AH control only)
T	Torque Limiter (45-140cc only; L0, AM, AN control only)

<sup>4</sup> Available on 28-140cc only

Port Orientation	
E	End Ports
S	Side Ports (60-140cc only)
R	Side Ports with ripple chamber (18-45cc only)
T	Side Ports with thru-drive

Displacement Stops <sup>5</sup>	
0	None
1	Adjustable maximum stop
2	Adjustable minimum stop
3	Adjustable maximum & minimum stop

<sup>5</sup> Not standard with thru drive. Contact factory for approval.

Work Port Type	
0	Flanged (Not with 18cc "E" or "R" ports)
2 <sup>6</sup>	Threaded (18-60cc only)

<sup>6</sup> On 60cc, only with SAE end ports

Thru-Drive Designation Description	
0	None
A	SAE 82-2 (A), 9T coupling
H	SAE 82-2 (A), 11T coupling
B	SAE 101-2 (B), 13T coupling (28-140cc only)
Q	SAE 101-2 (B), 15T coupling (28-140cc only)
C	SAE 127-4 (C), 14T coupling (60cc only) SAE 127-2/4 (C), 14T coupling (75-140cc only)
N	SAE 127-4 (C), 17T coupling (100 & 140cc only)
D	SAE 152-4 (D), 13T coupling (140cc only)

Paint	
00	No Paint
PB	Black Paint

Special Features	
00	Standard
M2	Special Designation

**Mounting Designation Descriptions**

Code	Standard	18	28	45	60	75 & 85	100	140
<b>S &amp; A</b>	SAE J744	SAE-A 2-Bolt	SAE-B 2-Bolt	SAE-B 2-Bolt	SAE-C 4-Bolt	SAE-C 4-Bolt	SAE-C 4-Bolt	SAE-D 4-Bolt
<b>M &amp; B</b>	ISO 3019/2	ISO 80mm 2-Bolt	ISO 100mm 2-Bolt	ISO 100mm 2-Bolt	ISO 125mm 4-Bolt	ISO 125mm 4-Bolt	ISO 125mm 4-Bolt	ISO 180mm 4-Bolt
<b>C &amp; D</b>	SAE J744	N/A	N/A	N/A	SAE-C 2-Bolt	SAE-C 2-Bolt	N/A	N/A
<b>J &amp; K</b>	SAE J744	N/A	N/A	N/A	SAE-B 2-Bolt	N/A	N/A	N/A

**Shaft Descriptions**

Code	18	28	45	60	75 & 85	100	140
<b>01</b>	SAE 11T spline	SAE-BB 15T spline	SAE-BB 15T spline	SAE-C 14T spline	SAE-C 14T spline	SAE-CC 17T spline	SAE-D 13T spline
<b>02</b>	SAE 19mm keyed	SAE-BB keyed	SAE-BB keyed	SAE-C keyed	SAE-C keyed	SAE-CC keyed	SAE-D keyed
<b>04</b>	ISO 20mm keyed	ISO 25mm keyed	ISO 25mm keyed	ISO 32mm keyed	ISO 32mm keyed	ISO 40mm keyed	DIN 50mm keyed
<b>06</b>	SAE-A 9T spline	N/A	N/A	N/A	N/A	SAE-C 14T spline	N/A
<b>08</b>	N/A	SAE-B 13T spline	SAE-B 13T spline	N/A	N/A	N/A	N/A
<b>09</b>	N/A	N/A	N/A	SAE-BB 15T spline	N/A	N/A	N/A
<b>10</b>	N/A	N/A	N/A	SAE-B 13T spline	N/A	N/A	N/A

**Maximum Flange Moment Ratings**

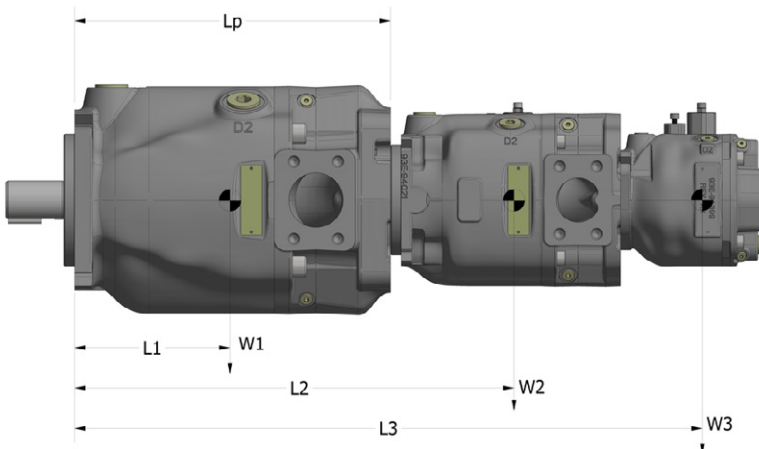

Moment  $M = (L1*W1+L2*W2+L3*W3...) \div 102$

Measurement	Units	P1/PD Displacement							
		18	28	45	60	75	85	100	140
Maximum Static Moment	Nm	500	650	1000	1200	1600	1600	2200	3200
Maximum Dynamic Moment (at 10g acceleration)	Nm	50	65	100	120	160	160	220	320
Distance L1 (no thru drive)	mm	73	93	107	110	119	119	154	154
Distance L1 (thru drive)	mm	104	113	115	123	134	134	179	185
Distance Lp	mm	199	233	229	253	264	264	340	364

**Shaft Torque Ratings**

		Units	18 (1.1)	28 (1.71)	45 (2.75)	60 (3.66)	75 (4.58)	85 (5.19)	100 (6.1)	140 (8.54)
<b>Maximum Input shaft torque</b>	<b>01</b>	Nm	134	337	337	641	641	641	1217	1701
		ft.lbs	99	249	249	473	473	473	898	1255
	<b>02</b>	Nm	130	357	357	559	559	559	1134	1732
		ft.lbs	96	264	264	413	413	413	837	1278
	<b>04</b>	Nm	113	337	337	576	576	576	1157	1708
		ft.lbs	84	249	249	425	425	425	854	1260
	<b>06</b>	Nm	58	N/A	N/A	N/A	N/A	N/A	641	N/A
		ft.lbs	43						473	
	<b>08</b>	Nm	N/A	209	209	N/A	N/A	N/A	N/A	N/A
		ft.lbs		155	155					
	<b>09</b>	Nm	N/A	N/A	N/A	337	N/A	N/A	N/A	N/A
		ft.lbs				249				
	<b>10</b>	Nm	N/A	N/A	N/A	209	N/A	N/A	N/A	N/A
		ft.lbs				155				
<b>Maximum through-drive shaft torque</b>		Nm	134	210	293	318	329	329	538	760
		ft.lbs	99	155	217	235	243	243	397	561

**Radial and Axial Shaft Load Ratings**

Radial Load Diagram

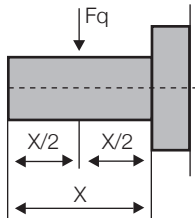

Axial Load Diagram

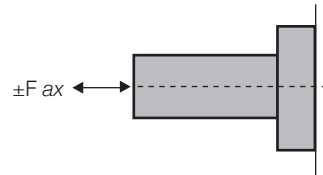

		<b>Maximum Allowable Shaft Load</b>								
		018	028	045	060	075	085	100	140	
<b>Radial Force (At X/2)</b>	<b>N</b>	700	1,000	1,500	1,800	1,900	1,900	2,300	2,600	
	<b>lbf</b>	160	229	343	411	434	434	526	594	
<b>Axial Force</b>	<b>N</b>	1,900	1,900	2,500	2,300	2,300	2,300	3,100	4,200	
	<b>lbf</b>	434	434	571	526	526	526	709	960	

**Shaft Rotational Stiffness**

Shaft Designation	Units	018		028		045		060		075/085		100		140	
		NRD	RD	NRD	RD	NRD	RD	NRD	RD	NRD	RD	NRD	RD	NRD	RD
<b>01</b>	ft-lb/Rad	4,332	3,475	7,712	6,458	11,681	10,540	18,198	15,397	20,615	16,838	31,080	25,479	47,819	43,970
	Nm/Rad	5,848	4,691	10,411	8,718	15,769	14,229	24,567	20,786	27,830	22,731	41,958	34,397	64,556	59,360
<b>02</b>	ft-lb/Rad	5,082	4,363	7,317	7,293	11,040	6,179	17,828	14,905	16,061	15,661	28,607	23,793	48,994	40,954
	Nm/Rad	6,861	5,890	9,878	9,846	14,904	8,342	24,068	20,122	21,682	21,142	38,619	32,121	66,142	55,288
<b>04</b>	ft-lb/Rad	4,468	3,903	7,011	5,958	9,362	8,715	16,771	14,006	14,994	14,646	25,529	21,625	53,685	44,181
	Nm/Rad	6,032	5,269	9,465	8,043	12,639	11,765	22,641	18,908	20,242	19,772	34,464	29,194	72,475	59,644
<b>06</b>	ft-lb/Rad	2,972	2,846	N/A		N/A		N/A		N/A		26,806	22,533	N/A	
	Nm/Rad	4,012	3,842	N/A		N/A		N/A		N/A		36,188	30,420	N/A	
<b>08</b>	ft-lb/Rad	5,699	5,044	7,320	6,180	10,124	9,255	N/A		N/A		N/A		N/A	
	Nm/Rad	7,694	6,809	9,882	8,343	13,667	12,494	N/A		N/A		N/A		N/A	
<b>09</b>	ft-lb/Rad	N/A		N/A		N/A		16,615	13,370	N/A		N/A		N/A	
	Nm/Rad	N/A		N/A		N/A		22,430	18,050	N/A		N/A		N/A	
<b>10</b>	ft-lb/Rad	N/A		N/A		N/A		11,696	10,472	N/A		N/A		N/A	
	Nm/Rad	N/A		N/A		N/A		15,790	14,137	N/A		N/A		N/A	

NRD = No rear thru drive; RD = Rear thru drive

